LED General Lighting by PLF™ Technology



製造所：KDT Co., LTD

販売代理店：株式会社マツボー

TEL：(03)5472-1722

FAX：(03)5472-1720

higuchi70@matsubo.co.jp

Company Introduction

General status

CEO	Young Wook Ko
Established in	Feb. 2004
Patents	74
Major products	Flat LED Lighting (GoDo Light Series)
Paid in capital	1.9 million USD
Seoul office	Suite 1104 Diplomat center in Seoul, Korea
Ochang fcry	Ochang science part , Chungbuk,Korea

History

2004

- Established laboratory
- Recognized as a venture company by small & medium sized company department
- Assigned as the one performing government driven projects by ministry of commerce, industry and energy
- Selected as a company who drives technical innovations by small and medium business administration
- Selected as a company with excellent new technology by the ministry information and communication
- Start mass production of PLF™

Ochang factory



2005

- Start mass production of PLF™
- Investment from Korea Development Bank

2006

- Selected by government as a business of component's material
- Strategic alliance contract with INNO DESIGN for LED lighting
- World's first adoption of LED lighting as general lighting for apartment of Hyundai construction company

2007

- Received Jang Young Sil award for technology of LED lighting
- achieved electrical safety marks (UL, CE, S-mark, EK...)
- achieved recognition of NET (New excellent technology)
- Set up Global marketing network (20 oversea network)



Key technology I

High CRI

Type of lighting source	CRI (color rendering index)
Sun light	100
PLF™ + pseudo white LED	75 ~ 95 (KDT)
Fluorescent lamps	80
Pseudo white LED	less than 75 (non-YAG phosphor)

Competitor
Product
(Low CRI)



PLF™

KDT
Product
(High CRI)



Strong Productivity

- ◆ Easy to procure the LEDs from LED suppliers
 - all ranks of LEDs can be used
 - LED leadtime will be shortened due to
 - price of LED will be less expensive
 - KDT can make the product cheaper and faster than others

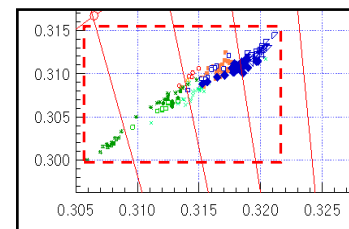

PLF™

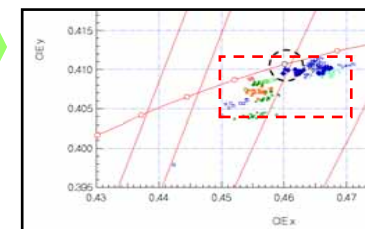

Key technology II

Color temperature Control (2700K ~ 6300K)

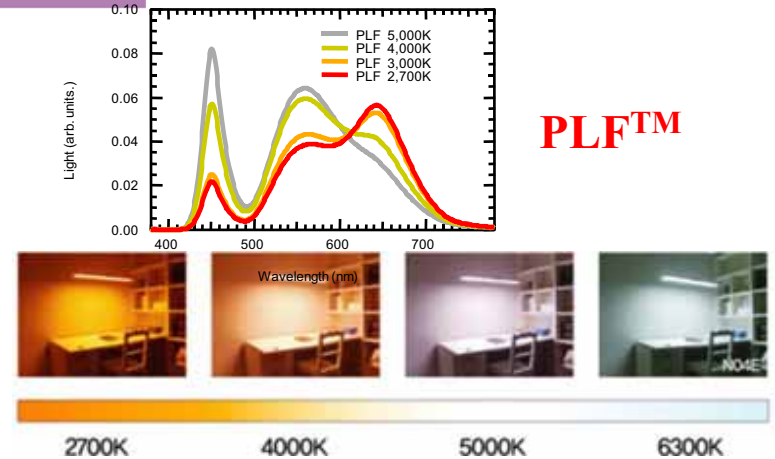
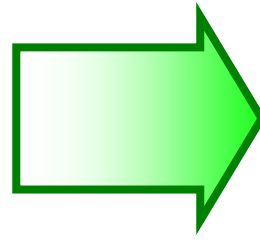
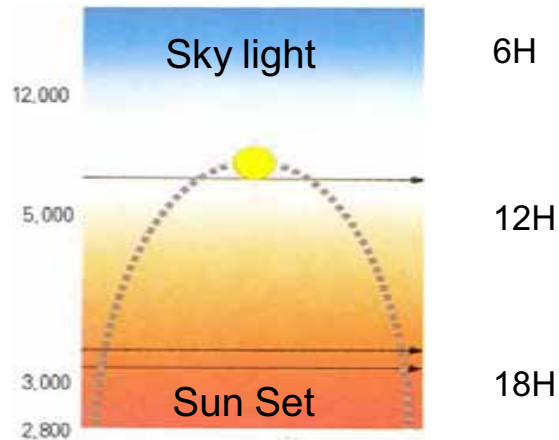

High Reliability

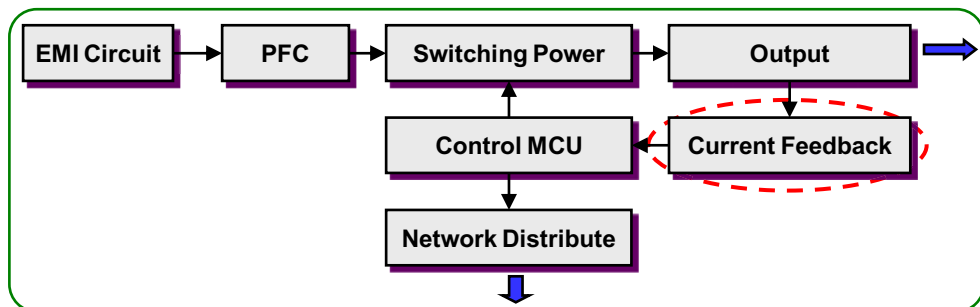

Constant current feedback power supply unit

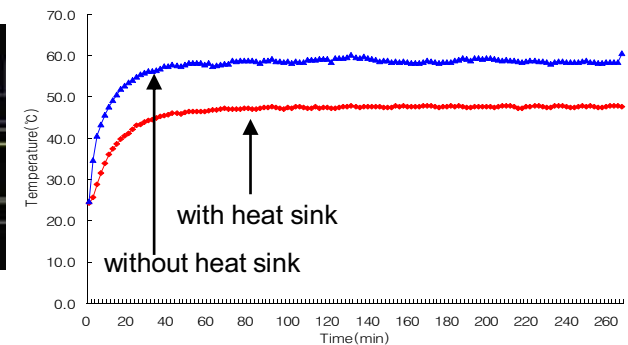
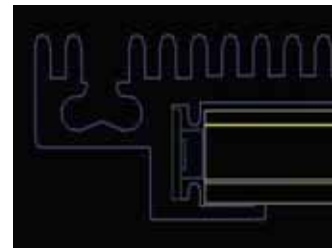

High reliability employing heat sink design of frame

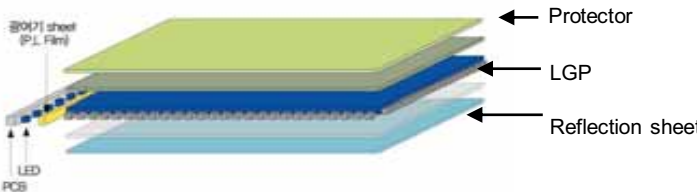
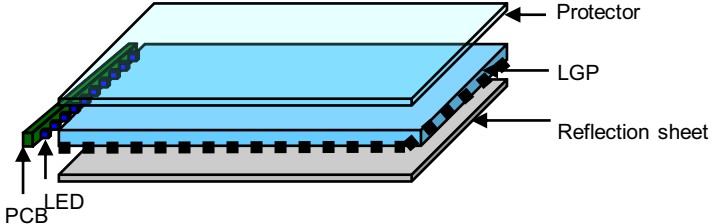
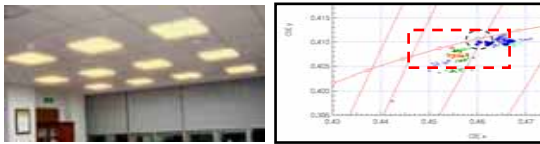
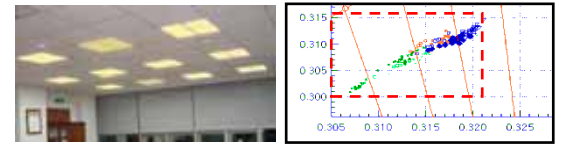

Comparative Table

Classification	KDT FLL™	Copiers ("F", "H", "S", "R" Co., and etc.)
<p>Structure</p>	<p>W LED + P.L.F.</p> 	<p>W LED only</p> 
<p>Low Cost Process</p>	<ul style="list-style-type: none"> * Low-cost, Emotional Light * CCT control (2,700K~6,300K) by PLF technology * All ranks of LEDs can be procured and used for FLL manufacturing → Strong Productivity 	<ul style="list-style-type: none"> * Emotional light at High-cost. * Week Productivity → When mass-produce, it's hard to procure LEDs at specific rank for the aimed color of the panel → Higher cost process 
<p>Stable & Low price LED Procurement</p>	<ul style="list-style-type: none"> * Strategic tie-up with LGI (LED supplier) * LG WLP technology applied (low-cost LED) 	<ul style="list-style-type: none"> * Instable LED procurement (total out sourcing)
<p>Natural Lighting</p>	<p>CRI (75 ~ 95)</p> <p>High CRI Excellent Color Uniformity</p> 	<p>CRI (70 under)</p> <p>Low CRI Bad Color Uniformity</p> 

Business Model



OEM I. Japan “E” Com. [E series]

KDT “OEM” Project

- Big 3 Lighting Company in Japan
- July '08 OEM product to be launched
- High-end Lighting Market

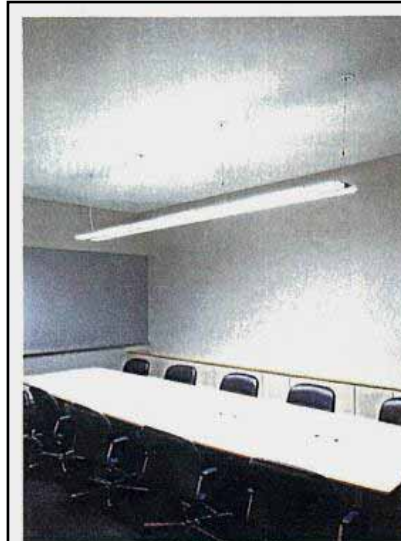

LED白色タイプ フル点灯時

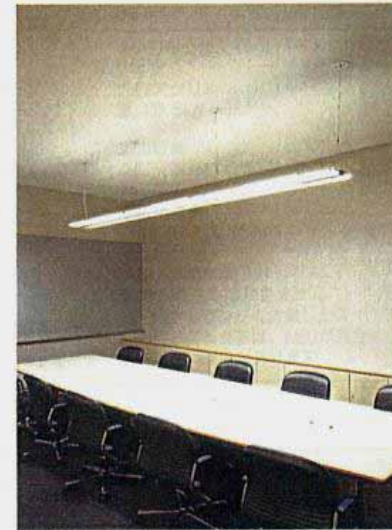

LED電球色タイプ フル点灯時

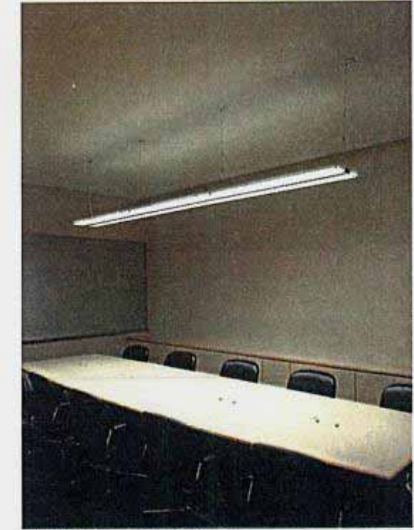

LED電球色タイプ 調光時

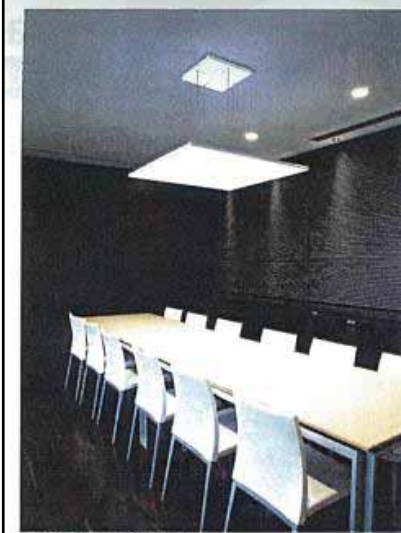

LED白色タイプ フル点灯時



LED電球色タイプ フル点灯時

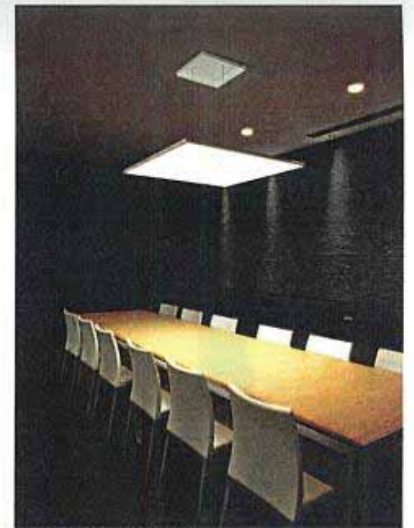

LED電球色タイプ 調光時

OEM II. Japan “T” Com.

KDT “OEM” Project

- #1 Construction Company in Japan
- Commercial & Residential application
- 40,000set guaranteed by 2012

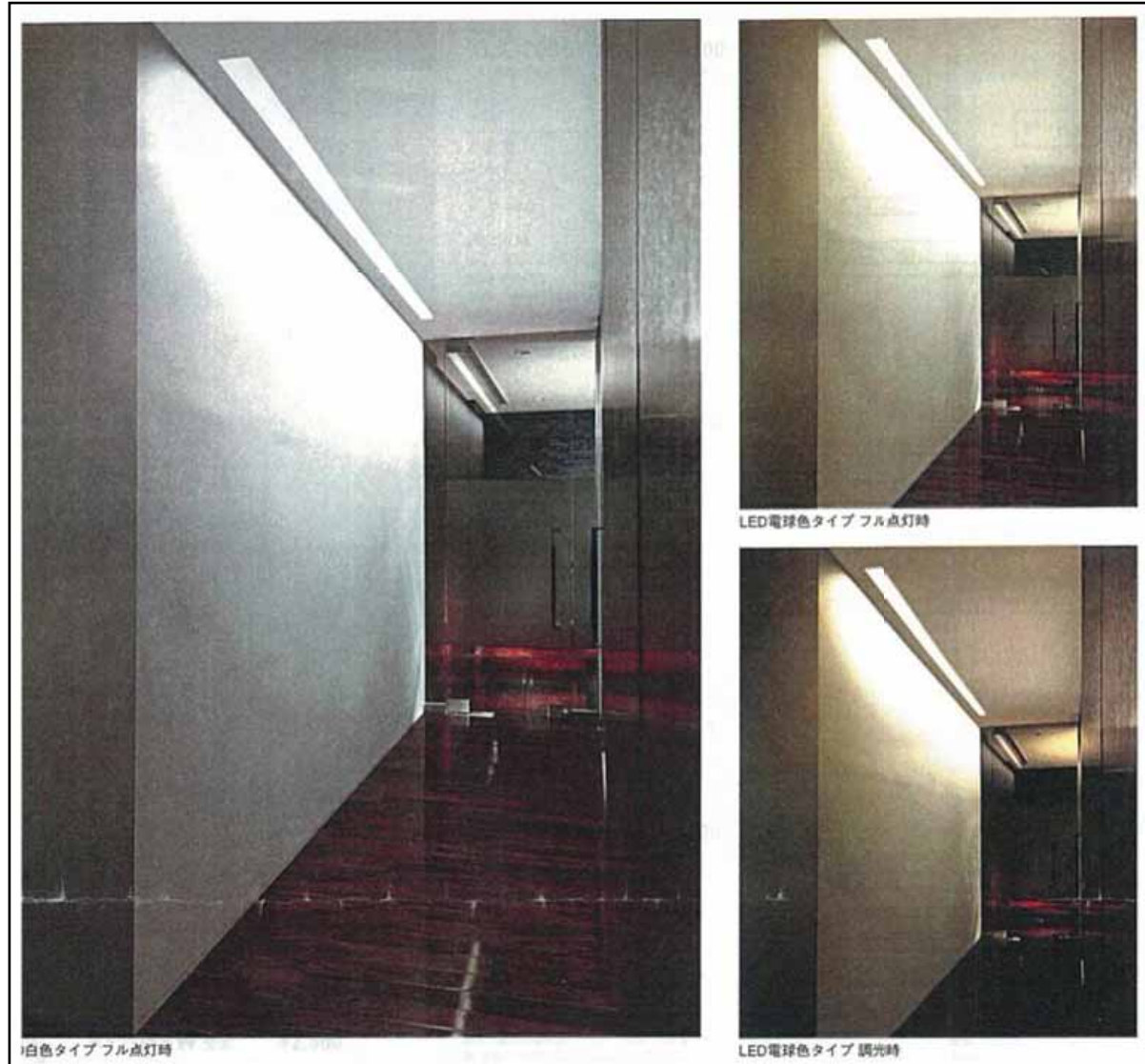

OEM III. Korea "L" Com.

KDT "OEM" Project

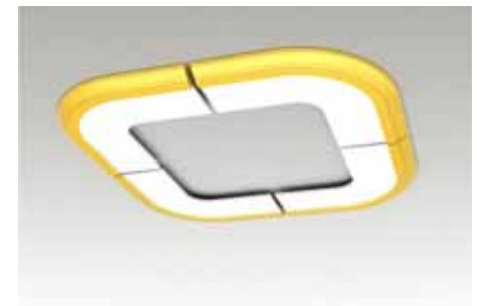
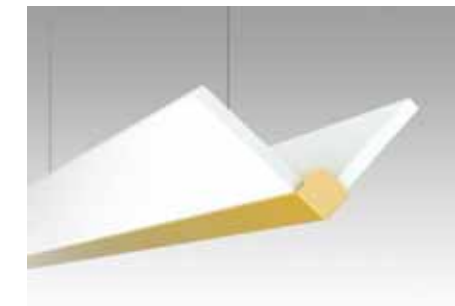
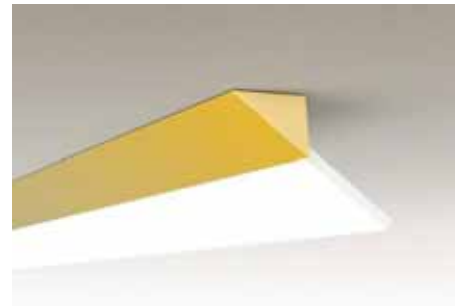
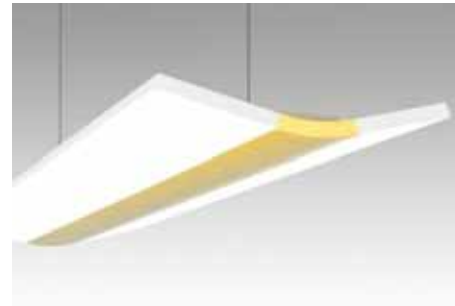

Overseas Distributor (“S” comp.)



Havells Sylvania

- Big 3 Lighting Company in Europe - # 1 in high-end lighting mkt.
- 1 billion dollar company with Havells of India
- 94 Representatives and 18 plants over 50 countries worldwide

• Strategic Partnership in Progress with Global Lighting Manufacturer

- Product Line-up Examining
- Supply Agreement Negotiating
- Plan to Launch under High-end Brand “Concord” by 3Q, '08 in whole European countries



- Demonstration in Sylvania Booth at Frankfurt Light fair, April 2008.

Ref. I. (Major Construction Companies)



Hillstate "Seoul Forest" Apartment

KDT Co.,Ltd : R36R1-W2	
Size	329 x 620 x 24
Power	62 W
Color Temp.	4000 K



Hillstate Model House

KDT Co.,Ltd : R312N1-E2	
Size	314 x 1180 x 33
Power	83 W
Color Temp.	2700~6300 K



StarCity Apartment / Richensia

KDT Co.,Ltd : R120T1-E1		KDT Co.,Ltd : R313T1-E2	
Size	97 x 2017 x 19	Size	320 x 1280 x 24
Power	65 W	Power	82 W
Color Temp.	6300 K	Color Temp.	2700~6300 K



Hillstate Aptment / study room (at DaeGu)

KDT Co.,Ltd : R29S1-E2	
Size	194 x 885 x 40
Power	60 W
Color Temp.	2700~6300 K



We've Apartment

KDT Co.,Ltd : S33T1-E2	
Size	307 x 307 x 24
Power	36 W
Color Temp.	2700~6300 K



We've Apartment

KDT Co.,Ltd : S33T1-E2	
Size	307 x 307 x 24
Power	36 W
Color Temp.	2700~6300 K

Ref. II. (Luxurious Villa)



KDT Co.,Ltd : S66T3-D2	
Size	600 x 600 x 24
Power	82 W
Color Temp.	6300 K



KDT Co.,Ltd : S66T3-D2	
Size	600 x 600 x 24
Power	82 W
Color Temp.	6300 K



KDT Co.,Ltd : S66T3-D2		KDT Co.,Ltd : R313T1-E2	
Size	600 x 600 x 24	Size	320 x 1280 x 24
Power	82 W	Power	82 W
Color Temp.	6300 K	Color Temp.	2700~6300 K



KDT Co.,Ltd : S66T3-D2	
Size	600 x 600 x 24
Power	82 W
Color Temp.	6300 K



KDT Co.,Ltd : R120T1-E1	
Size	97 x 2017 x 19
Power	65 W
Color Temp.	6300 K



KDT Co.,Ltd : R120T1-E1	
Size	97 x 2017 x 19
Power	65 W
Color Temp.	6300 K

Ref. III. (DaeWoo, "Frujio" Model House)



KDT Co.,Ltd : R120T1-E1	
Size	97 x 2017 x 19
Power	65 W
Color Temp.	6300 K



KDT Co.,Ltd : R120T1-E1	
Size	97 x 2017 x 19
Power	65 W
Color Temp.	6300 K



KDT Co.,Ltd : S66T3-E2	
Size	600 x 600 x 24
Power	84 W
Color Temp.	2700~6300 K



KDT Co.,Ltd : R120T1-E1	
Size	97 x 2017 x 19
Power	65 W
Color Temp.	6300 K



KDT Co.,Ltd : R110T1-E1	
Size	97 x 1028 x 19
Power	36 W
Color Temp.	2700~6300 K



KDT Co.,Ltd : R36T1-D2		KDT Co.,Ltd : S33T1-D1	
Size	329 x 619 x 24	Size	307 x 307 x 19
Power	62 W	Power	22 W
Color Temp.	6300 K	Color Temp.	6300 K

Ref IV. (Apartments & Residential)



Luxury Villa (at YongIn)

KDT Co.,Ltd : S66T3-E2	
Size	600 x 600 x 24
Power	84 W
Color Temp.	2700~6300 K



Private Residential

KDT Co.,Ltd : S33T1-E2	
Size	307 x 307 x 24
Power	36 W
Color Temp.	2700~6300 K



Good Moring Hill (at KyongGi-Do)

KDT Co.,Ltd : S66T2-D1	
Size	600 x 600 x 19
Power	60 W
Color Temp.	6300 K



Kitchen at private villa

KDT Co.,Ltd : R313T1-E2	
Size	320 x 1280 x 24
Power	82 W
Color Temp.	2700~6300 K



Model House for Hillstate Model house

KDT Co.,Ltd : R36R1-D2	
Size	329 x 620 x 24
Power	62 W
Color Temp.	6300 K



Model House at Hillstate Model House

KDT Co.,Ltd : S66T3-E2	
Size	600 x 600 x 24
Power	84 W
Color Temp.	2700~6300 K

Ref V. (Office Building)



Conference room at Chungbuk Univ.



Lobby at LS tower



DSME office

KDT Co.,Ltd : S66T2-D1		KDT Co.,Ltd : R36T1-D2	
Size	600 x 600 x 19	Size	329 x 619 x 24
Power	60 W	Power	62 W
Color Temp.	6300 K	Color Temp.	6300 K

KDT Co.,Ltd : R110T1-W2	
Size	97 x 1028 x 24
Power	65 W
Color Temp.	4000 K

KDT Co.,Ltd : R36T1-D2	
Size	329 x 619 x 24
Power	62 W
Color Temp.	6300 K



Office of Cheil worldwide Inc.



Inno Design office



Floor lighting at Walkerhill Hotel

KDT Co.,Ltd : S66T2-D1	
Size	600 x 600 x 19
Power	60 W
Color Temp.	6300 K

KDT Co.,Ltd : C6S1-E2	
Size	600 x 24
Power	67 W
Color Temp.	2700~6300 K

KDT Co.,Ltd : S66T3-E2	
Size	600 x 600 x 24
Power	84 W
Color Temp.	2700~6300 K

Ref. VI. (Government Building)



Elevator hall at Korea University

KDT Co.,Ltd : S33T1-D2	
Size	307 x 307 x 24
Power	36 W
Color Temp.	6300 K



Service Area

KDT Co.,Ltd : S33T1-D2	
Size	307 x 307 x 24
Power	36 W
Color Temp.	6300 K



Lobby at Chungbuk University

KDT Co.,Ltd : S66T2-D1	
Size	600 x 600 x 19
Power	60 W
Color Temp.	6300 K



Service Area at CheonAn

KDT Co.,Ltd : S66T2-D1	
Size	600 x 600 x 19
Power	60 W
Color Temp.	6300 K



Street light at Guro Station

KDT Co.,Ltd : S66T3-D1	
Size	600 x 600 x 19
Power	42 W
Color Temp.	6300 K



Lobby at Chungbuk University

KDT Co.,Ltd : S66T2-D1	
Size	600 x 600 x 19
Power	60 W
Color Temp.	6300 K

Ref. VII. (Overseas)



Audi show room at Germany

KDT Co.,Ltd : S33T1-D2	
Size	307 x 307 x 24
Power	36 W
Color Temp.	6300 K



Office of "R" company at Germany

KDT Co.,Ltd : S66T3-W2	
Size	600 x 600 x 24
Power	82 W
Color Temp.	4000 K



BMW office

KDT Co.,Ltd : S33T1-D1	
Size	307 x 307 x 19
Power	22 W
Color Temp.	6300 K



Green Building Council at Australia

KDT Co.,Ltd : S33T1-D2	
Size	307 x 307 x 24
Power	36 W
Color Temp.	6300 K



Bainsdale Elementary school at Australia

KDT Co.,Ltd : S66T3-D1	
Size	600 x 600 x 19
Power	42 W
Color Temp.	6300 K



Miki Museum at Japan

KDT Co.,Ltd : S66T3-E2	
Size	600 x 600 x 24
Power	88 W
Color Temp.	6300 K

Ref. VII. (Overseas)



McDonald

KDT Co.,Ltd : S66T2-D1	
Size	600 x 600 x 19
Power	60 W
Color Temp.	6300 K



McDonald